

-XX IN THE ENDING OF THE CABLE PART NUMBER IS CALLING OUT THE LENGTH OF THE ASSEMBLY FROM CENTER TO MATING FLANGE OF CONNECTORS. EXAMPLES SHOWN BELOW:

LTI P/N: CBG-2SALRF3GT-4IN (4 INCHES)
 CBG-2SALRF3GT-10IN (10 INCHES)

REVISIONS				
REV	ECR	DESCRIPTION	DRAWN	DATE
1		PRODUCTION RELEASE	M. LARSEN	03/08/2023

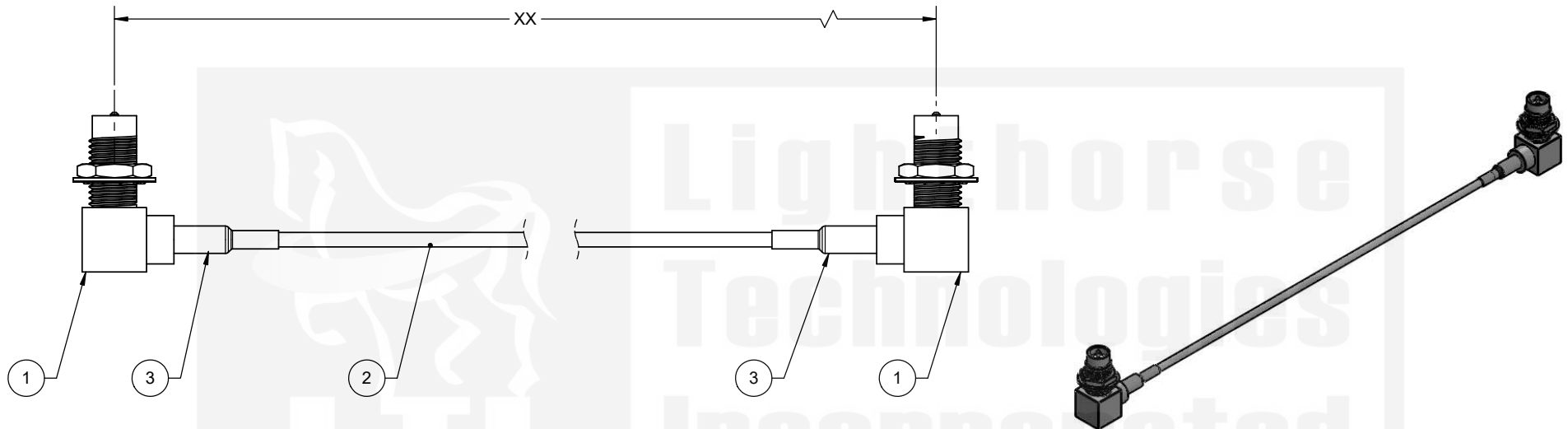

ITEM	PART NUMBER	DESCRIPTION	QTY
1	SALRF13RGT-316	RP-SMA, RIGHT ANGLE, REV POL JACK, BLKHD MNT, CABLE CRIMP	2
2	RG-178	CABLE, RG-178 COAX, COPPER COLOR	AR
3	1635F-1/8"	.125 (1/8) DIA, .75 LENGTH, GREEN	2

DO NOT SCALE DRAWING			Lighthouse Technologies	
TOLERANCES UNLESS OTHERWISE SPECIFIED			San Diego, CA WWW.RFCONNECTOR.COM	
DIMENSIONS ARE IN MILLIMETERS			TITLE: CABLE ASSEMBLY, RP-SMA, R/A JACK, BLKHD MNT, CRIMP TO RP-SMA, R/A JACK, BLKHD MNT, CRIMP USING RG-178 CABLE	
X = ±0.5 XX = ±0.25 XXX = ±0.13 ANGLE = ±30°			SIZE	PART/DWG. NO:
CUSTOMER APPROVAL		B	CBG-2SALRF3GT-XX	A
SIGN / DATE:		SCALE: 2:1 FILE NAME		
ENG APPR.	P. BURDGE	03/08/2023		
CHECKED	M. HELD	03/08/2023		
DRAWN	M. LARSEN	03/08/2023		
NAME	DATE	SHEET 1 OF 1		

PROPRIETARY AND CONFIDENTIAL

UNLESS OTHERWISE SPECIFIED: THIS DOCUMENT CONTAINS LIGHORSE TECHNOLOGIES INFORMATION. REPRODUCTION, USE, DISCLOSURE OR TRANSMITTAL OF ALL OR ANY PART OF THIS DOCUMENT IS PROHIBITED EXCEPT TO THE EXTENT APPROVED IN WRITING BY AN AUTHORIZED REPRESENTATIVE OF LIGHORSE TECHNOLOGIES. LIGHORSE TECHNOLOGIES RESERVES ALL RIGHTS UNDER PATENTS, TRADEMARKS, COPYRIGHTS AND TRADE SECRETS. COPY RIGHTS OF LIGHORSE TECHNOLOGIES 2011, ALL RIGHTS RESERVED.

