

LENGTH TOLERANCE FOR CABLE ASSEMBLIES	
Inches	Millimeters
0 - 2IN +/- 0.040	0 - 51 +/- 1
2IN - 6IN +/- 0.080	51 - 153 +/- 2
6IN - 12IN +/- 0.140	153 - 305 +/- 3.5
12IN - 48IN +/- 0.250	305 - 1219 +/- 6.4
48IN - 144IN (12FT) +/- 0.500	1219 - 3658 +/- 13
144IN (12FT) - ABOVE +/- 1.0	3658 - ABOVE +/- 25
UNLESS OTHERWISE SPECIFIED ON DRAWING	

-XX IN THE ENDING OF THE CABLE PART NUMBER IS CALLING OUT THE LENGTH OF THE ASSEMBLY FROM CENTER TO MATING FLANGE OF CONNECTORS. EXAMPLES SHOWN BELOW:

LTI P/N EXAMPLES: CBD-SAF3GT-SALRF3GT-4IN (4 INCHES)  
 CBD-SAF3GT-SALRF3GT-100MM (100 MILLIMETERS)

REVISIONS				
REV	ECR	DESCRIPTION	DRAWN	DATE
1		ENGINEERING RELEASE	M. LARSEN	03-25-2024

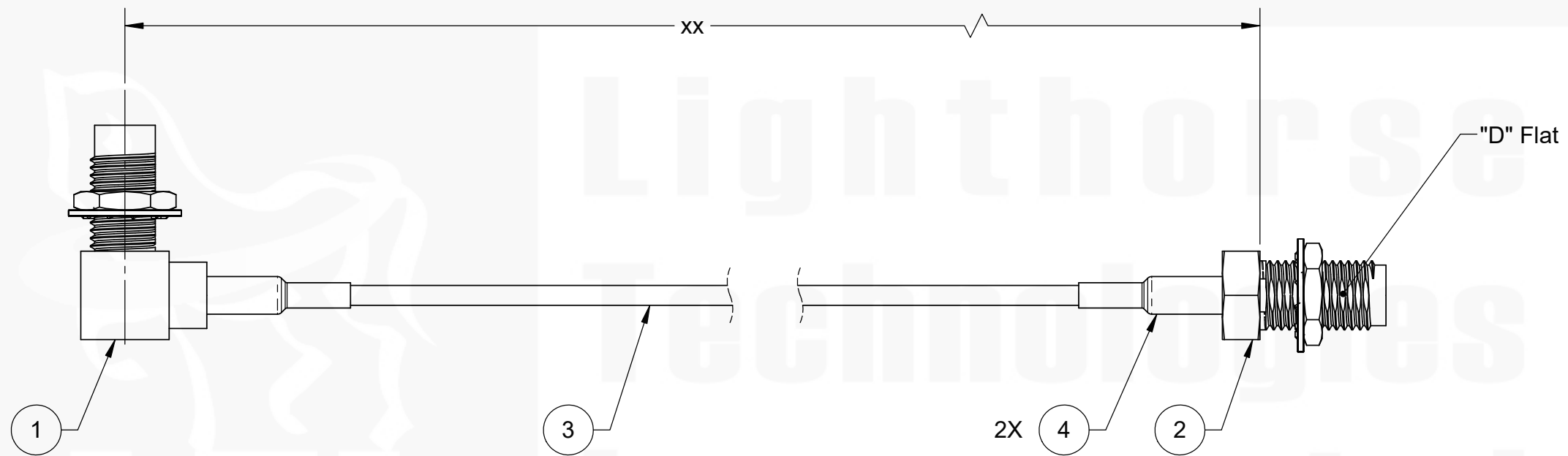

ITEM	PART NUMBER	DESCRIPTION	QTY
1	SALRF13RGT-316	RP-SMA, RIGHT ANGLE, REV POL JACK, BLKHD MNT, CABLE CRIMP	1
2	SASF13RGT-316	SMA, STRAIGHT, JACK, BLKHD MNT, CABLE CRIMP	1
3	RG-316	CABLE, RG-316 COAX	AR
4	1635F-3/16"	.1875 (3/16) DIA, .75 LENGTH, GREEN	2

DO NOT SCALE DRAWING		 <b>Lighthouse Technologies</b> San Diego, CA WWW.RFCONNECTOR.COM
TOLERANCES UNLESS OTHERWISE SPECIFIED		
DIMENSIONS ARE IN MILLIMETERS X = ±0.5 X.X = ±0.25 X.XX = ±0.13 ANGLE = ±30'		TITLE: CABLE ASSEMBLY, SMA, JACK, BLKHD MNT, CRIMP TO RP-SMA, R/A JACK, BLKHD MNT, CRIMP USING RG-316 COAX
THIRD ANGLE PROJECTION		
CUSTOMER APPROVAL		
SIGN / DATE:		SIZE: B
ENG APPR:		PART/DWG. NO: CBD-SAF3GT-SALRF3GT-xx
CHECKED:		REV: 1
DRAWN: M. LARSEN	3-25-2024	SCALE: 2:1
NAME:	DATE:	FILE NAME:
		SHEET 1 OF 1

PROPRIETARY AND CONFIDENTIAL  
 UNLESS OTHERWISE SPECIFIED: THIS DOCUMENT CONTAINS LIGHTHORSE TECHNOLOGIES INFORMATION. REPRODUCTION, USE, DISCLOSURE OR TRANSMITTAL OF ALL OR ANY PART OF THIS DOCUMENT IS PROHIBITED EXCEPT TO THE EXTENT APPROVED IN WRITING BY AN AUTHORIZED REPRESENTATIVE OF LIGHTHORSE TECHNOLOGIES. LIGHTHORSE TECHNOLOGIES RESERVES ALL RIGHTS UNDER PATENTS, TRADEMARKS, COPYRIGHTS AND TRADE SECRETS. COPY RIGHTS OF LIGHTHORSE TECHNOLOGIES 2011, ALL RIGHTS RESERVED.

